

THIS DRAWING IS UNPUBLISHED. RELEASED FOR PUBLICATION  
 © COPYRIGHT BY TYCO ELECTRONICS CORPORATION. ALL RIGHTS RESERVED.

LOC	DIST	REVISIONS					
		P	LTR	DESCRIPTION	DATE	DWN	APVD
G	86		K	REDRAWN PER 0G3A-0400-04	02JUN04	JR	MS

- 1 TONGUE MATERIAL THICKNESS .048±.003
- △ 2 BODY: COPPER PER ASTM B-152  
TIN PER ASTM B-545  
INSULATION: PVC, COLOR - YELLOW  
METALLIC SLEEVE: COPPER PER ASTM B-152  
METALLIC BAND: STEEL PER ASTM A109
- 3 FOR .436 MAX WIRE INSULATION DIA

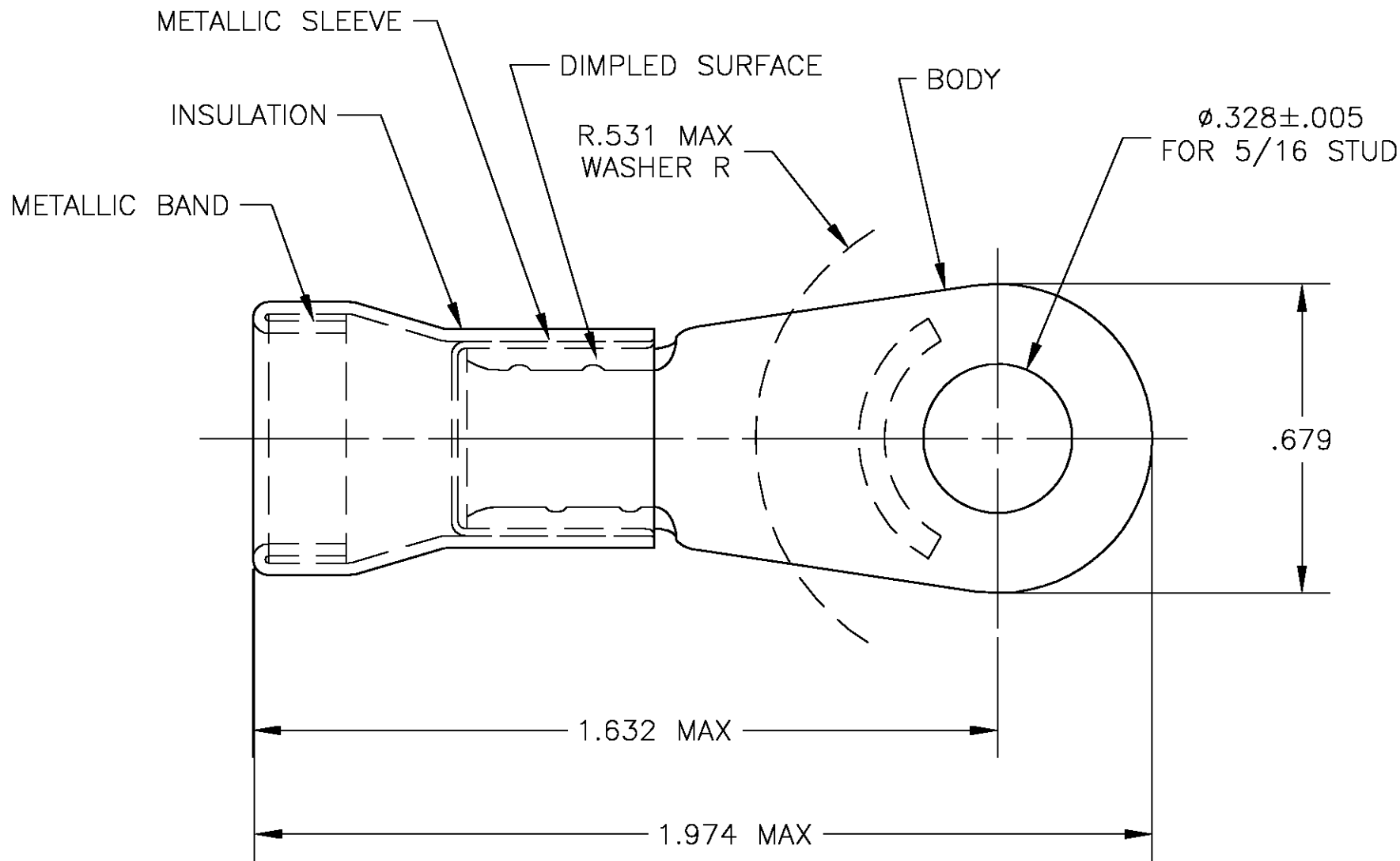

P/N ON TAPE	QTY	DESCRIPTION	PART NO
2-322010-4	1	WIRE TERMINAL	322010

THIS DRAWING IS A CONTROLLED DOCUMENT.		DWN jr_ruth	02JUN04	<b>tyco</b> <b>Electronics</b>	Tyco Electronics Corporation Harrisburg, PA 17105		
DIMENSIONS: INCHES		CHK MJ SPICER	02JUN04		NAME TERMINAL, AMPLI-BOND, RING TONGUE WIRE SIZE: 4		
TOLERANCES UNLESS OTHERWISE SPECIFIED:		APVD MJ SPICER	02JUN04	PRODUCT SPEC			
0 PLC ± -		APPLICATION SPEC		SIZE			
1 PLC ± -		WEIGHT		CAGE CODE			
2 PLC ± -		CUSTOMER DRAWING		DRAWING NO			
3 PLC ± .008		SCALE 3:1		SHEET 1 OF 1			
4 PLC ± -		REV K		RESTRICTED TO			
ANGLES ± 5°							
FINISH							
- △ 2							